

LC05732ARA

Battery Protection IC, Integrated Power MOSFET, 1-Cell Lithium-Ion Battery

Overview

The LC05732ARA is a protection IC for 1-cell lithium-ion batteries with integrated power MOS FET. Also it integrates highly accurate detection circuits and detection delay circuits to prevent batteries from over-charging, over-discharging, over-current discharging and over-current charging.

In addition, main system can execute the power-on reset of itself by turning off the charge FET and discharge FET of LC05732ARA for a certain time period, with a reset signal.

A battery protection system can be made by only LC05732ARA and few external parts.

Features

- Charge-and-Discharge Power MOSFET are Integrated at $T_A = 25^\circ\text{C}$, $V_{CC} = 4.0\text{ V}$
 - ◆ ON Resistance (Total of Charge and Discharge) $4.8\text{ m}\Omega$ (typ)
- Highly Accurate Detection Voltage/Current at $T_A = 25^\circ\text{C}$, $V_{CC} = 3.7\text{ V}$
 - ◆ Over-Charge Detection $\pm 25\text{ mV}$
 - ◆ Over-Discharge Detection $\pm 50\text{ mV}$
 - ◆ Charge Over-Current Detection $\pm 0.7\text{ A}$
 - ◆ Discharge Over-Current Detection $\pm 0.7\text{ A}$
- Delay Time for Detection and Release (Fixed Internally)
- Discharge/Charge Over-Current Detection is Compensated for Temperature Dependency of Power FET
- 0 V Battery Charging: "Inhibit"
- Auto Wake-up Function Battery Charging: "Inhibit"
- Forcible Charge-FET and Discharge-FET OFF Mode
 $R_{STB} > V_{DD} * 0.9$: Charge-FET and Discharge-FET = ON
 $R_{STB} < V_{DD} * 0.1$: Charge-FET and Discharge-FET = OFF
- These Devices are Pb-Free, Halogen Free/BFR Free and are RoHS Compliant

Typical Applications

- Smart Phone
- Tablet
- Wearable Device



ON Semiconductor®

www.onsemi.com

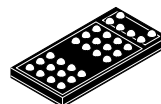

ECP30, 1.97x4.01
SUFFIX
CASE 971BC

MARKING DIAGRAM

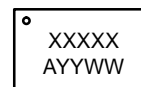

A = Assembly Location
YY = Year
WW = Work Week

ORDERING INFORMATION

Device	Package	Shipping†
LC05732A02RATBG	ECP30 (Pb-Free)	5000 / Tape & Reel
LC05732A03RATBG	ECP30 (Pb-Free)	5000 / Tape & Reel

†For information on tape and reel specifications, including part orientation and tape sizes, please refer to our Tape and Reel Packaging Specification Brochure, BRD8011/D.

LC05732ARA

SPECIFICATIONS

ABSOLUTE MAXIMUM RATINGS at $T_A = 25^\circ\text{C}$ (Notes 1, 2, 3, 5)

Parameter	Symbol	Conditions	Ratings	Unit
Supply voltage	VCC	Between PAC+ and VCC : $R1 = 680\ \Omega$	-0.3 to 12.0	V
S1 – S2 voltage	VS1–S2		20.0	V
CS terminal Input voltage	CS		$V_{CC}-20.0$ to $V_{CC}+0.3$	V
RSTB input voltage	RSTB		-0.3 to 7	V
Storage temperature	Tstg		-55 to +125	$^\circ\text{C}$
Operating ambient temperature	Topr		-40 to +100	$^\circ\text{C}$
Allowable power dissipation	Pd	(Note 4)	800	mW
Junction temperature	T_J		125	$^\circ\text{C}$

Stresses exceeding those listed in the Maximum Ratings table may damage the device. If any of these limits are exceeded, device functionality should not be assumed, damage may occur and reliability may be affected.

1. Absolute maximum ratings represent the values which cannot be exceeded at any given time
2. If you intend to use this IC continuously under high temperature, high current, high voltage, or drastic temperature change, even if it is used within the range of absolute maximum ratings or operating conditions, there is a possibility of decrease reliability. Please contact us for confirmation
3. This device is made for power applications.
4. JESD 51-3 (1S)
5. Please execute appropriate test and take safety measures on your board.

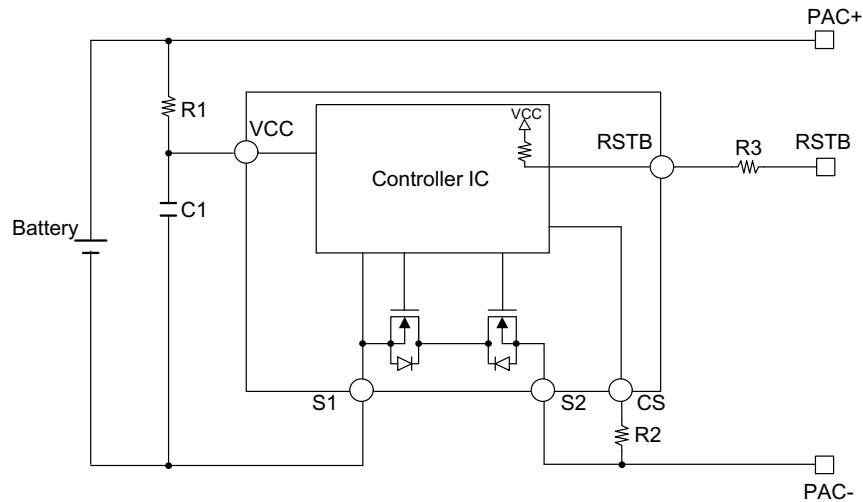

Figure 1. Example of Application Circuit

Components	Min	Recommended Value	Max	Unit	Description
R1	330	680	1k	Ω	
R2	680	1k	2k	Ω	
R3	680	1k	2k	Ω	
C1	0.1 μ	1.0 μ	2.2 μ	F	

*We don't guarantee the characteristics of the circuit shown above.

LC05732ARA

ELECTRICAL CHARACTERISTICS (Notes 6, 7, 8, 9)

Parameter	Symbol	Conditions	Min	Typ	Max	Unit	
DETECTION VOLTAGE							
Over-charge detection voltage	Vov	R1 = 680 Ω	TA = 25°C	Vov_set -25	Vov_set	Vov_set +25	mV
			TA = -30 to 70°C	Vov_set -30	Vov_set	Vov_set +30	
Over-charge release voltage	Vovr	R1 = 680 Ω	TA = 25°C	Vovr_set -40	Vovr_set	Vovr_set +40	mV
			TA = -30 to 70°C	Vovr_set -70	Vovr_set	Vovr_set +70	
Over-discharge detection voltage	Vuv	R1 = 680 Ω	TA = 25°C	Vuv_set -50	Vuv_set	Vuv_set +50	mV
			TA = -30 to 70°C	Vuv_set -80	Vuv_set	Vuv_set +80	
Over-discharge release voltage	Vuvr	R1=680 Ω CS =0V	TA = 25°C	Vuvr_set -100	Vuvr_set	Vuvr_set +100	mV
			TA = -30 to 70°C	Vuvr_set -120	Vuvr_set	Vuvr_set +120	
Discharge over-current detection current	loc	R2 = 1 kΩ	TA = 25°C V _{CC} = 3.7 V	loc_set -0.7	loc_set	loc_set +0.7	A
			TA = -30 to 70°C V _{CC} = 3.7 V	loc_set -1.2	loc_set	loc_set +1.2	
Discharge over-current detection current2 (Short circuit)	loc2	R2 = 1 kΩ	TA = 25°C V _{CC} = 3.7 V	loc2_set*0.8	loc2_set	loc2_set*1.2	A
			TA = -30 to 70°C V _{CC} = 3.7 V	loc2_set*0.6	loc2_set	loc2_set*1.8	
Charge over-current detection current	loch	R2 = 1 kΩ	TA = 25°C V _{CC} = 3.7 V	loch_set -0.7	loch_set	loch_set +0.7	A
			TA = -30 to 90°C V _{CC} = 3.7 V	loch_set -1.2	loch_set	loch_set +1.2	

RESET TERMINAL

High-Level Input Voltage	VIH		TA = -30 to 90°C	0.9*V _{CC}			V
Low-Level Input Voltage	VIL		TA = -30 to 90°C			0.1*V _{CC}	V
High-Level Input Leakage Current	I _{IH}	V _{CC} = RSTB	TA = -30 to 90°C			1	μA
Low-Level Input Leakage Current	I _{IL}	V _{CC} = 3.7 V RSTB = 0 V	TA = -30 to 90°C	20	34	48	μA
Reset pulse width	Tw_res	V _{CC} = 2.2 to 4.3 V	TA = -30 to 90°C	10	20	30	ms

INPUT VOLTAGE

0 V battery charging inhibition battery voltage	Vinh		TA = 25°C	0.4	0.9	1.4	V
---	------	--	-----------	-----	-----	-----	---

CURRENT CONSUMPTION

Operating current	ICC	At normal state	TA = 25°C V _{CC} = 3.7 V		3	6	μA
Shut down current	Ishut	At shut down state	TA = 25°C V _{CC} = 2.0 V			0.1	μA

RESISTANCE

ON resistance 1 of integrated power MOSFET	Ron1	V _{CC} = 3.1 V	TA = 25°C	4.4	5.4	6.9	mΩ
		I = ±2.0 A					
ON resistance 2 of integrated power MOS FET	Ron2	V _{CC} = 3.8 V	TA = 25°C	4	4.9	5.8	mΩ
		I = ±2.0 A					
ON resistance 3 of integrated power MOSFET	Ron3	V _{CC} = 4.0 V	TA = 25°C	3.9	4.8	5.7	mΩ
		I = ±2.0 A					

LC05732ARA

ELECTRICAL CHARACTERISTICS (Notes 6, 7, 8, 9)

Parameter	Symbol	Conditions	Min	Typ	Max	Unit	
RESISTANCE							
ON resistance 4 of integrated power MOSFET	Ron4	$V_{CC} = 4.5V$	TA = 25°C	3.8	4.7	5.6	mΩ
		I = ±2.0 A					
Internal resistance (VCC-CS)	Rcsu	$V_{CC} = V_{uv_set}$ CS = 0 V	TA = 25°C		300		kΩ
Internal resistance (VSS-CS)	Rcsd	$V_{CC} = 3.7 V$ CS = 0.1 V	TA = 25°C		10		kΩ
Forward Source to Source Voltage	Vf(s-s)	$V_{CC} = 2.0 V$ Is = 0.25 A	TA = 25°C		0.67	1.06	V

DETECTION AND RELEASE DELAY TIME

Over-charge detection delay time	Tov		TA = 25°C	0.8	1	1.2	s
			TA = -30 to 70°C	0.6	1	1.5	
Over-charge release delay time	Tovr		TA = 25°C	12.8	16	19.2	ms
			TA = -30 to 70°C	9.6	16	24	
Over-discharge detection delay time	Tuv		TA = 25°C	14	20	26	ms
			TA = -30 to 70°C	12	20	30	
Over-discharge release delay time	Tuvr		TA = 25°C	0.9	1.1	1.3	ms
			TA = -30 to 70°C	0.6	1.1	1.5	
Discharge over-current detection delay time 1	Toc1	$V_{CC} = 3.7 V$	TA = 25°C	9.6	12	14.4	ms
			TA = -30 to 70°C	7.2	12	18	
Discharge over-current release delay time 1	Tocr1	$V_{CC} = 3.7 V$	TA = 25°C	3.2	4	4.8	ms
			TA = -30 to 70°C	2.4	4	6	
Discharge over-current detection delay time 2 (Short circuit)	Toc2	$V_{CC} = 3.7 V$	TA = 25°C	230	300	420	μs
			TA = -30 to 70°C	200	300	450	
Charge Over-current detection delay time	Toch	$V_{CC} = 3.7 V$	TA = 25°C	12.8	16	19.2	ms
			TA = -30 to 90°C	9.6	16	24	
Charge Over-current release delay time	Tochr	$V_{CC} = 3.7 V$	TA = 25°C	3.2	4	4.8	ms
			TA = -30 to 90°C	2.4	4	6	
Reset release time	Tres	$V_{CC} = 3.7 V$	TA = 25°C	0.8	1	1.2	s
			TA = -30 to 70°C	0.6	1	1.5	

6. This device is made for power applications.
7. Please execute appropriate test and take safety measures on your board.
8. Product parametric performance is indicated in the Electrical Characteristics for the listed test conditions, unless otherwise noted. Product performance may not be indicated by the Electrical Characteristics if operated under different conditions.
9. The specification in this parameter and all specification at high and low temperature are guaranteed by design.

LC05732ARA

SELECTION GUIDE

Device	Vov (V)	Vovr (V)	Vuv (V)	Vuvr (V)	loc (A)	loch (A)	loc2 (A)	Tuv (ms)	Reset Function
LC05732A02RATBG	4.475	4.475	2.1	2.1	7.0	9.0	25.0	20	Enable
LC05732A03RATBG	4.500	4.300	2.3	2.3	9.0	6.0	15.0	20	Disable

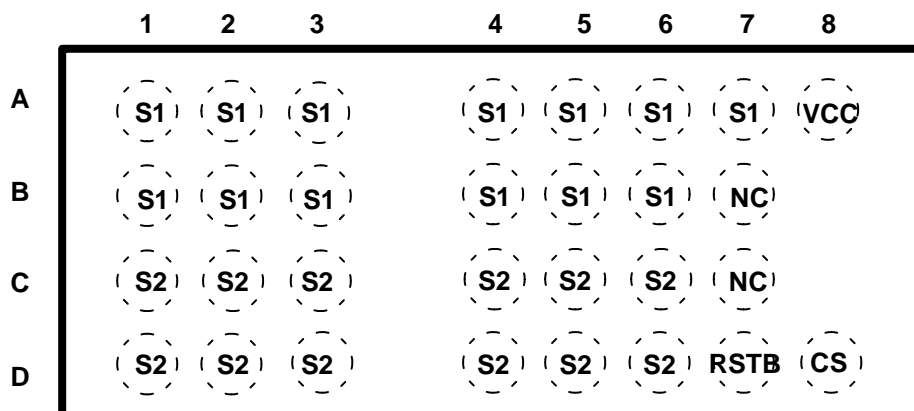

TOP VIEW

Figure 2. Pin Functions

Pin No.	Symbol	Pin Function	Description
A1-7 B1-6	S1	Source 1	Negative power input
A8	VCC	VCC terminal	
C1-6 D1-6	S2	Source 2	
D7	RSTB	Charge and discharge off control terminal ("L" = Reset)	Connected to VCC with 100 kΩ
D8	CS	Charger minus voltage input terminal	
B7,C7	NC	Non connection	

LC05732ARA

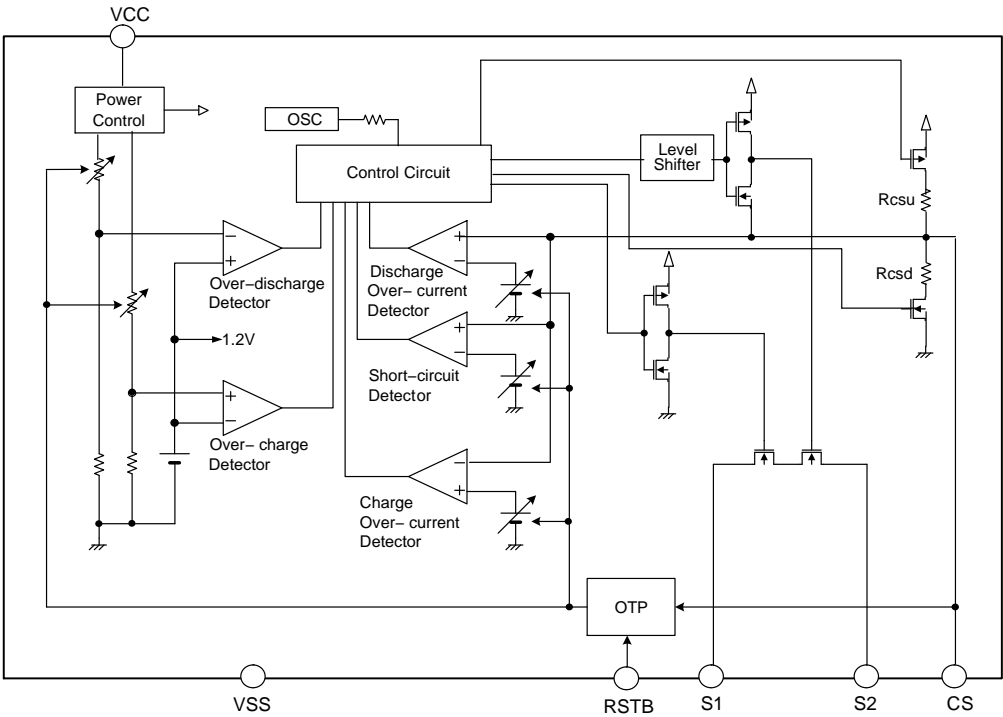

Figure 3. Block Diagram

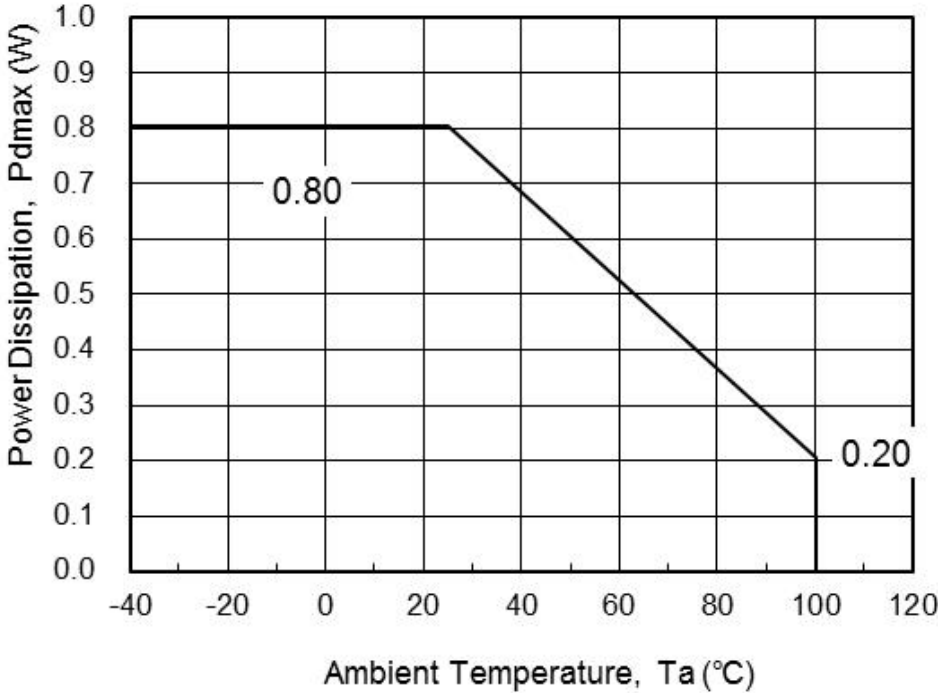

Figure 4. Pdmax vs TA

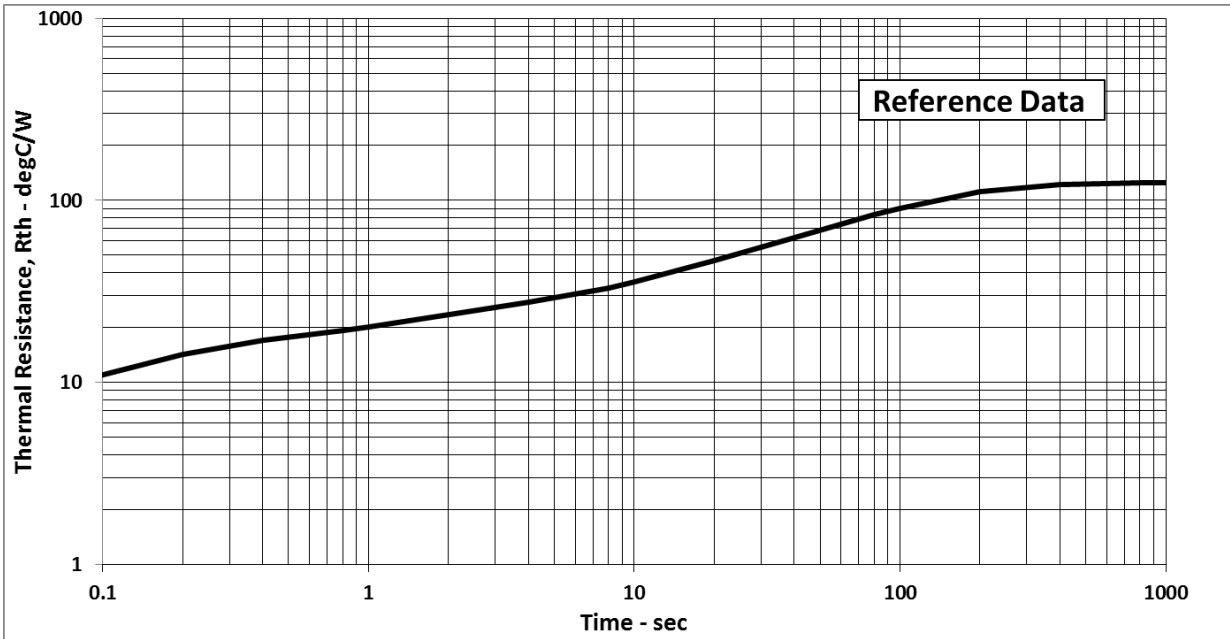

Figure 5. Thermal Resistance vs Time

DESCRIPTION OF OPERATION

1. Normal mode
 - ◆ LC05732ARA controls charging and discharging by detecting cell voltage (VCC) and controls S2–S1 current. In case that cell voltage is between over–discharge detection voltage (Vuv) and over–charge detection voltage (Vov), and S2–S1 current is between charge over–current detection current (Ioch) and discharge over–current detection current (Ioc), internal power MOS FETs as CHG_SW, DCHG_SW are both turned ON. This is the normal mode, and it is possible to be charged and discharged.
2. Over–charging mode
 - ◆ Internal power MOSFET CHG_SW turns off if cell voltage becomes greater than or equal to over–charge detection voltage (Vov) over the delay time of over–charging (Tov). This is the over–charging detection mode.
 - ◆ The recovery from over–charging will be made after the following two conditions are satisfied.
 1. Charger is removed from IC.
 2. Cell voltage decreases under over–charge release voltage (Vovr) over the delay time of over–charging releasing (Tovr) due to discharging through a load. Consequently, internal power MOS FET as CHG_SW will be turned on and normal mode will be resumed.
 - ◆ In over–charging mode, discharging over–current detection is made only when CS pin increases more than discharging over–current detection current 2(Ioc2), because discharge current flows through parasitic diode of CHG_SW FET. If CS pin voltage increases more than discharging over–current detection current 2 (Ioc2) over the delay time of discharging over–current 2 (Toc2), discharging will be shut off, because internal power FETs as DCHG_SW is turned off. (short–circuit detection mode)

After detecting short–circuit, CS pin will be pulled down to VSS by internal resistor Rcsd.
 - ◆ The recovery from short circuit detection in over–charging mode will be made after the following two conditions are satisfied.
 1. Load is removed from IC.
 2. CS pin voltage becomes less than or equal to discharging over–current detection current 2 (Ioc2) due to CS pin pulled down through Rcsd. Consequently, internal power MOS FET as DCHG_SW will be turned on, and over–charging detection mode will be resumed.
3. Over–discharging mode without Auto Wake Up function
 - ◆ If cell voltage drops lower than over–discharge detection voltage (Vuv) over the delay time of over–discharging (Tuv), discharging will be shut off, internal power FETs as DCHG_SW is turned off. This is the over–discharging mode.

After detecting over–discharging, CS pin will be pulled up to VCC by an internal resistor Rcsu and the bias of internal circuits will be shut off. (Shut–down mode)

In shut–down mode, operating current is suppressed under 0.1 uA (max).
 - ◆ The recovery from stand–by mode will be made by internal circuits biased after the connecting charger.
 - ◆ By continuing to be charged, if cell voltage increases more than over–discharge detection voltage (Vuvr) over the delay time of over–discharging (Tuvr), internal power MOS FETs as DCHG_SW is turned on and normal mode will be resumed.
4. Discharging over–current detection mode 1
 - ◆ In over–discharge detection mode, charging over–current detection does not operate. By continuing to be charged, charging over–current detection starts to operate after cell voltage goes up more than over–discharge release voltage (Vuvr).
 - ◆ Internal power MOS FET as DCHG_SW will be turned off and discharging current will be shut off if CS pin voltage becomes greater than or equal to discharging over–current detection current (Ioc) over the delay time of discharging over–current (Toc1). This is the discharging over–current detection mode 1.

In discharging over–current detection mode 1, CS pin will be pulled down to VSS with internal resistor Rcsd.
 - ◆ The recovery from discharging over–current detection mode will be made after the following two conditions are satisfied.
 1. Load is removed from IC.
 2. CS pin voltage becomes less than or equal to discharging over–current release current (Iocr) over the delay time of discharging over–current release (Tocr1) due to CS pin pulled down through Rcsd. Consequently, internal power MOS FET as DCHG_SW will be turned on, and normal mode will be resumed.
5. Discharging over–current detection mode 2 (short circuit detection)
 - ◆ Internal power MOS FET as DCHG_SW will be turned off and discharging current will be shut off if CS pin voltage becomes greater than or equal to discharging over–current detection current2 (Ioc2) over the delay time of discharging over–current 2 (Toc2). This is the short circuit detection mode.

- ◆ In short circuit detection mode, CS pin will be pulled down to VSS by internal resistor Rcsd. The recovery from short circuit detection mode will be made after the following two conditions are satisfied.
 - a. Load is removed from IC.
 - b. CS pin voltage becomes less than or equal to discharging over-current release current (Iocr) over the delay time of discharging over-current release (Tocr1) due to CS pin pulled down through Rcsd. Consequently, internal power MOS FET as DCHG_SW will be turned on, and normal mode will be resumed.
- 6. Charging over-current detection mode
- ◆ Internal power MOS FET as CHG_SW will be turned off and charging current will be shut off if CS pin voltage becomes less than or equal to charging over-current detection current (Ioch) over the delay time of charging over-current (Toch). This is the charging over-current detection mode.
- ◆ The recoveries from charging over-current detection mode will be made after the following two conditions are satisfied.
 1. Charger is removed from IC and CS pin will increase by load connection.
 2. CS pin voltage becomes greater than or equal to charging over-current release current (Iochr) over the delay time of charging over-current release (Tochr). Consequently, internal power MOS FET as CHG_SW will be turned on, and normal mode will be resumed.

*Internal current flows out through CS and S2 terminals.

After charger is removed, it flows through parasitic diode of CHG_SW FET.

Therefore, CS pin voltage will go up more than charging over-current release current (Iochr).

So CS pin voltage is not an indispensable condition for recovery from charging over-current detection.

7. 0 V Battery Protection Function

This function protects the battery when a short circuit in the battery (0 V battery) is detected, at which point charging will be prohibited.

When the voltage of a battery is below 1.4 V (max), the gate of the charging control FET is fixed to the PAC-Terminal voltage, at which point charging will be prohibited.

If the voltage of the battery is greater than the 0 V battery prohibit voltage (Vinh), charging will be enabled.

8. Reset mode

- ◆ In case of normal mode, internal power MOS FET as CHG_SW and DCHG_SW will be turned off and charging and discharging current will be shut off if RSTB pin voltage becomes less than or equal to low-level input voltage (VIL) over the delay time of reset pulse width(Tw_res).

This is the reset mode.

- ◆ The recovery from reset mode will be made itself after the reset release time (Tres). Consequently, internal power MOS FET as CHG_SW and DCHG_SW will be turned on, and normal mode will be resumed.

LC05732ARA

TIMING CHART

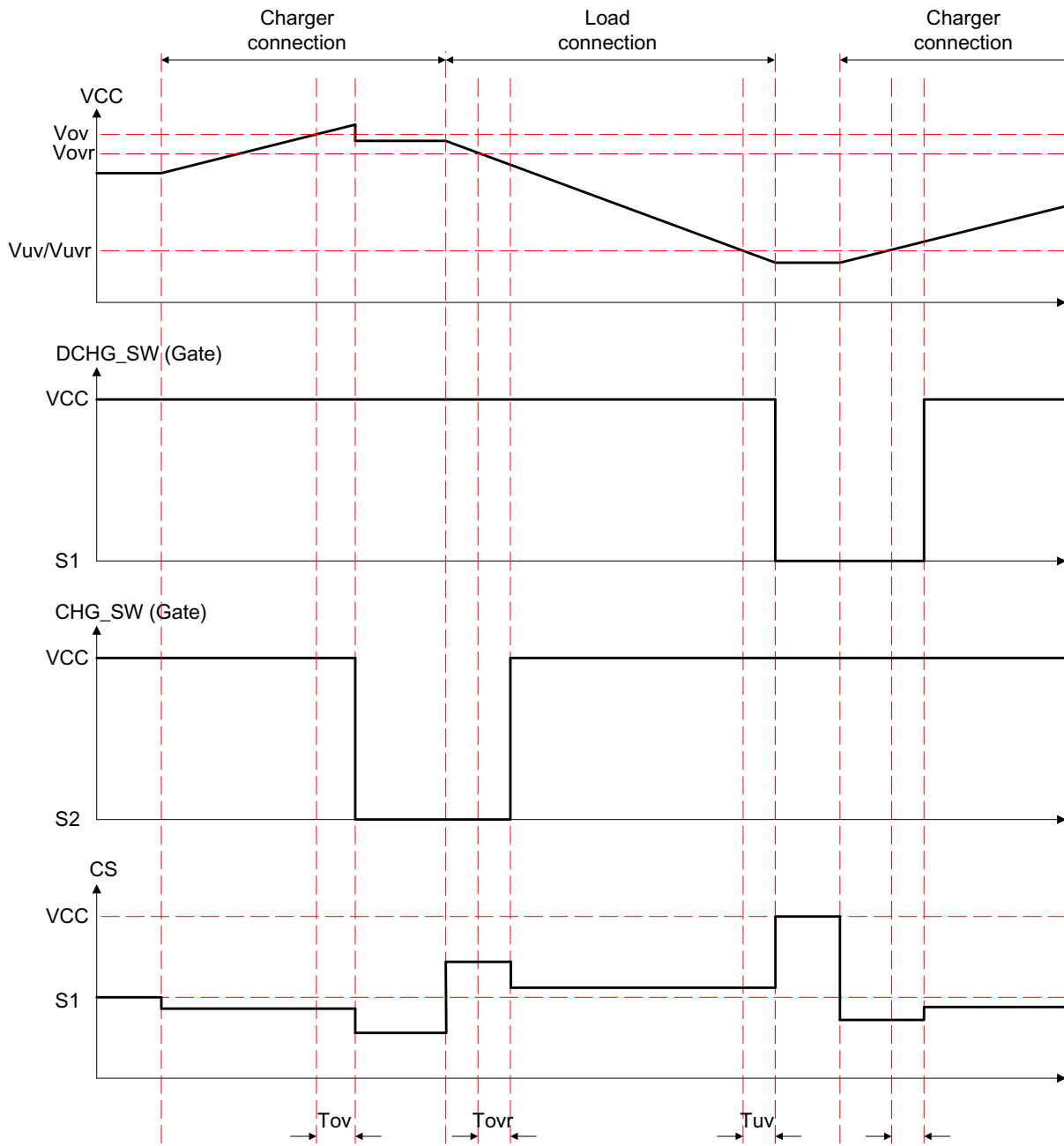

Figure 6. Over-charge Detection/Release, Over-discharge Detection/Release (Connect Charger)

LC05732ARA

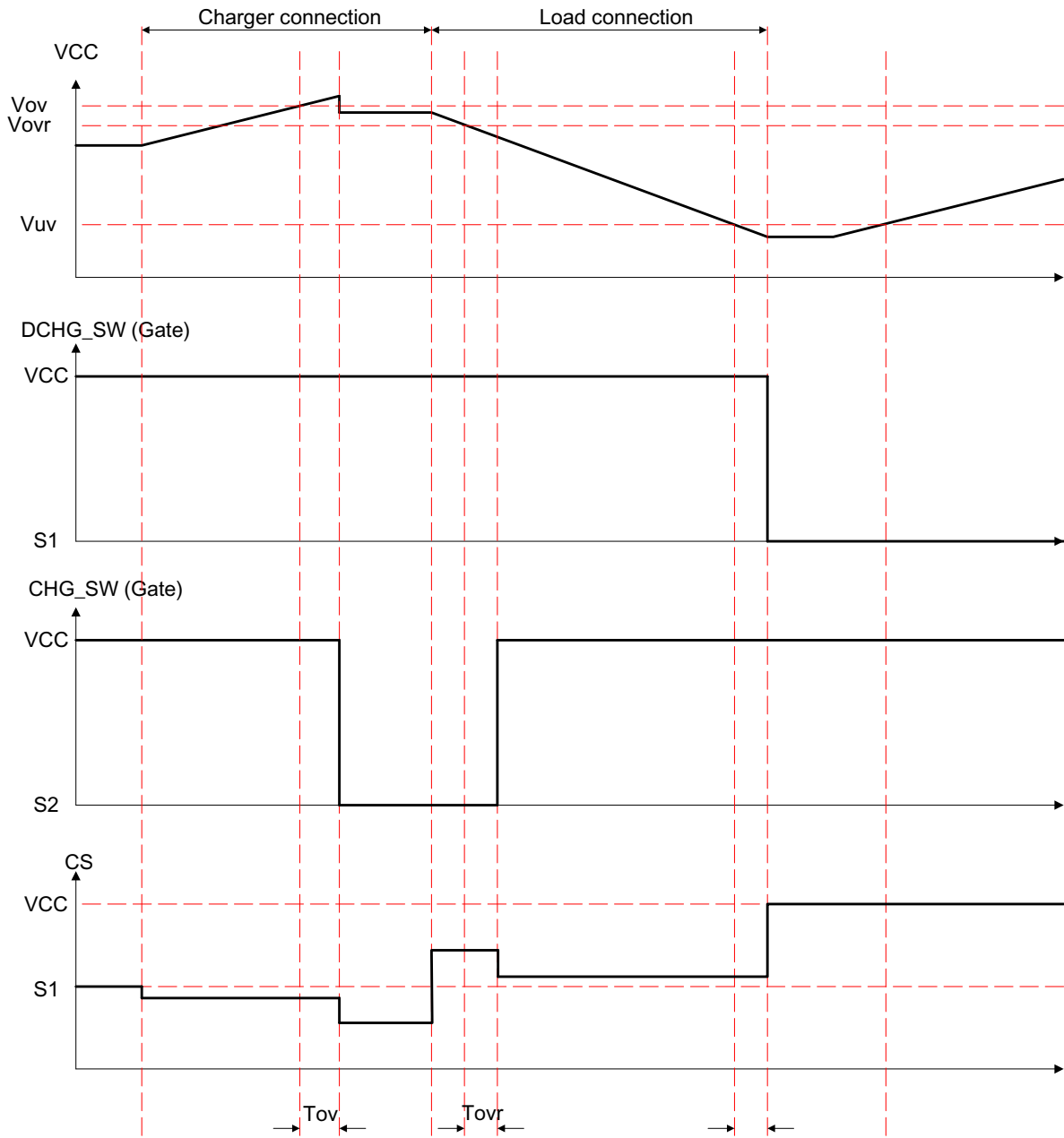

Figure 7. Over-charge Detection/Release, Over-discharge Detection/Release (Non-connect Charger)

LC05732ARA

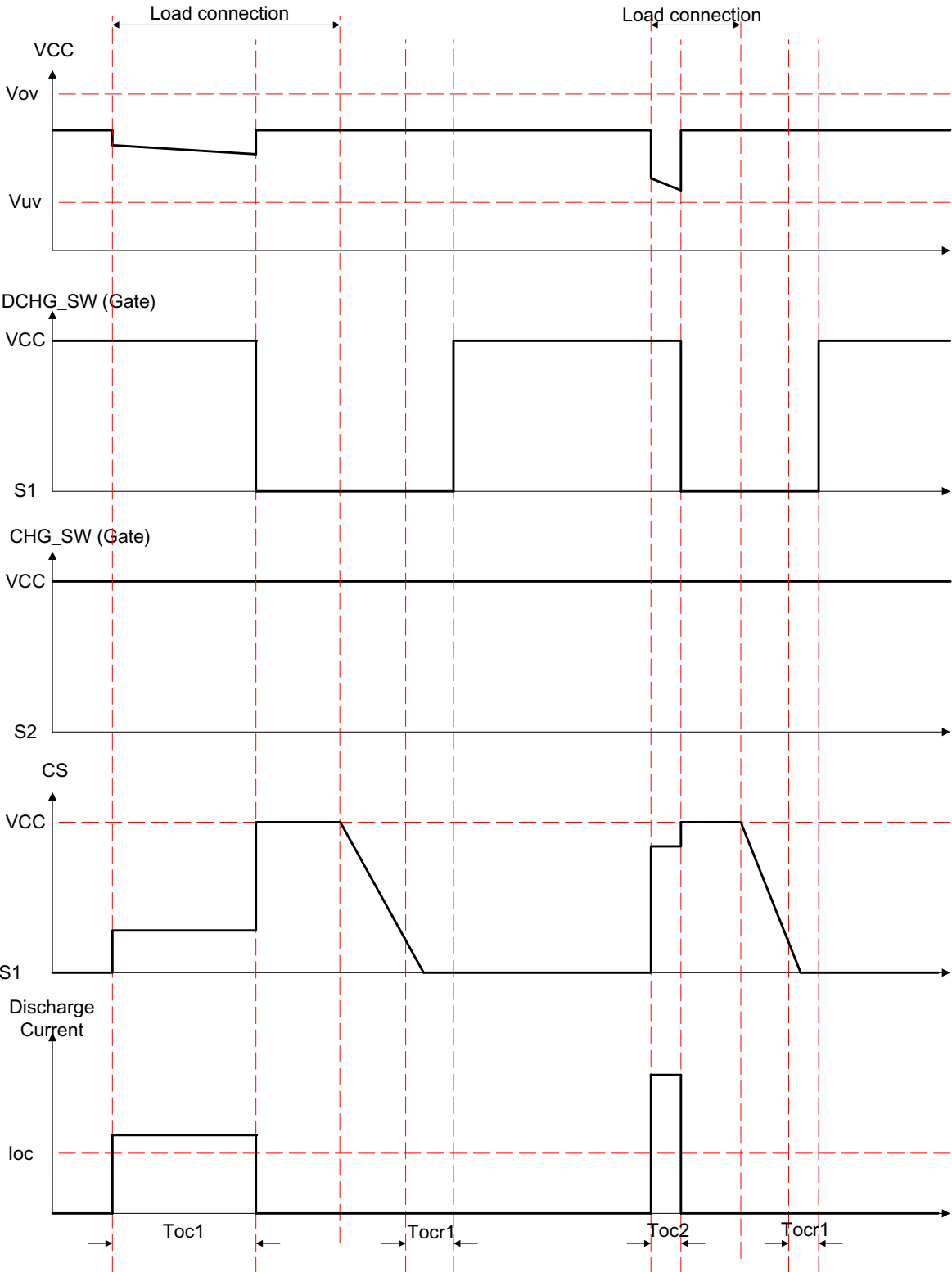

Figure 8. Discharge Over-Current Detection1, Discharge Over-current Detection2 (Short Circuit)

LC05732ARA

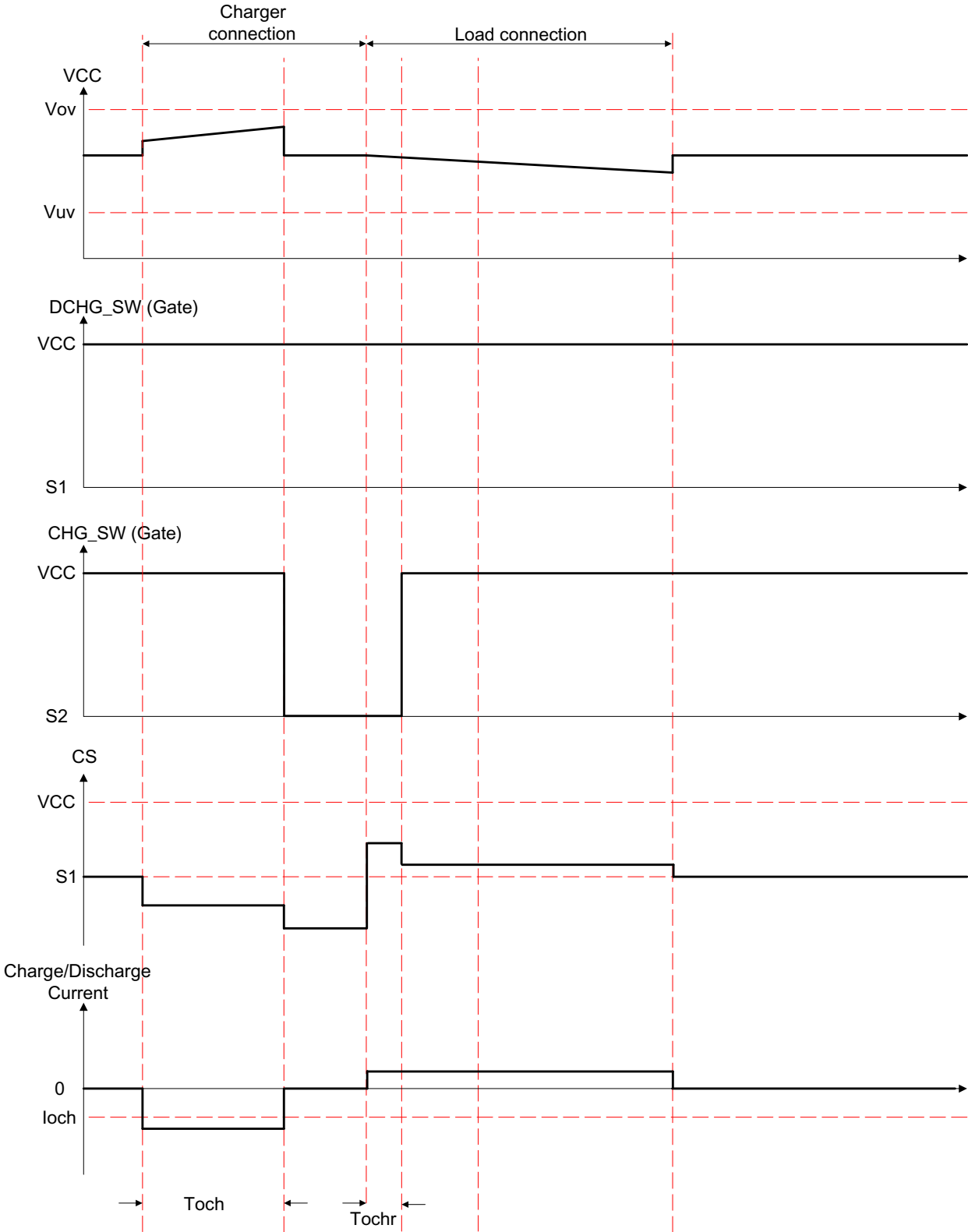

Figure 9. Charge Over-current Detection

LC05732ARA

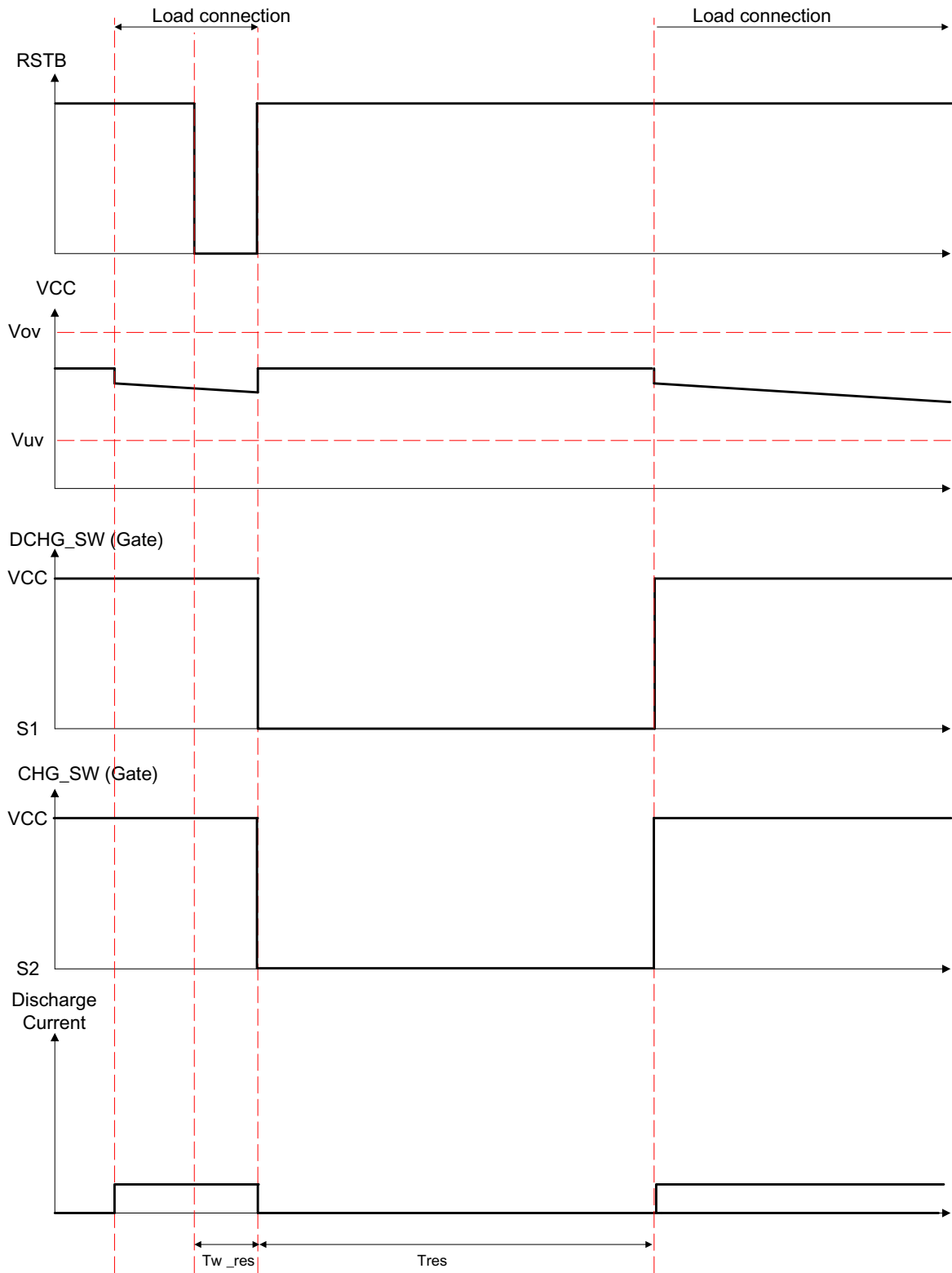
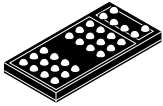

Figure 10. Reset Function

MECHANICAL CASE OUTLINE

PACKAGE DIMENSIONS

ON Semiconductor®



SCALE 4:1

ECP30, 1.97x4.01
CASE 971BC
ISSUE A

DATE 23 FEB 2016

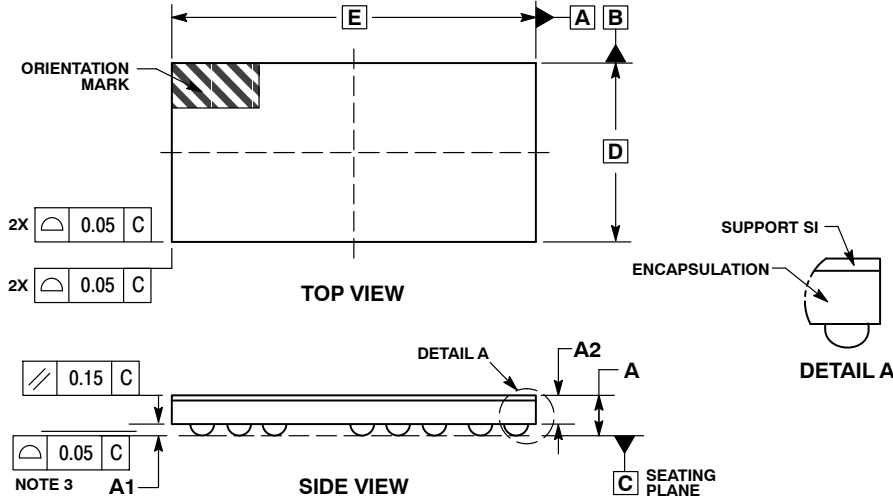

- NOTES:
1. DIMENSIONING AND TOLERANCING PER ASME Y14.5M, 1994.
 2. CONTROLLING DIMENSION: MILLIMETERS.
 3. COPLANARITY APPLIES TO THE SPHERICAL CROWNS OF THE SOLDER BALLS.
 4. DIMENSION b IS MEASURED AT THE MAXIMUM BALL DIAMETER PARALLEL TO DATUM C.

DIM	MILLIMETERS	
	MIN	MAX
A	0.545	0.625
A1	0.165	0.205
A2	0.380	0.420
b	0.245	0.285
D	1.970 BSC	
E	4.010 BSC	
E2	0.860 BSC	
E3	0.100 BSC	
E4	1.405 BSC	
e	0.400 BSC	

GENERIC MARKING DIAGRAM*

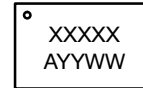

A = Assembly Location
YY = Year
WW = Work Week

*This information is generic. Please refer to device data sheet for actual part marking. Pb-Free indicator, "G" or microdot "•", may or may not be present.

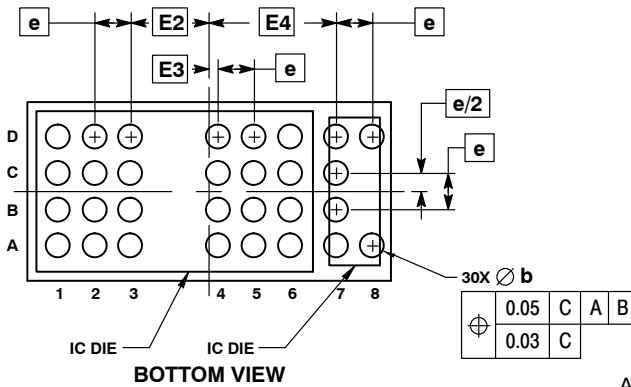

RECOMMENDED SOLDERING FOOTPRINT*

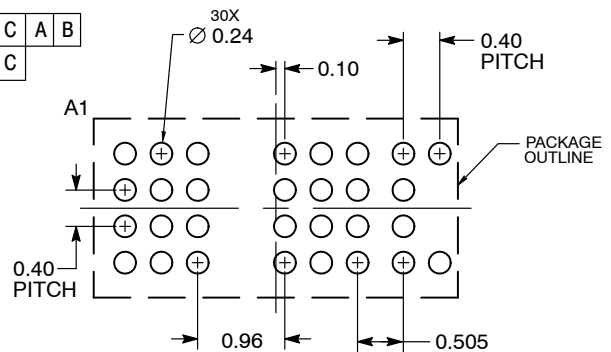

DIMENSIONS: MILLIMETERS

*For additional information on our Pb-Free strategy and soldering details, please download the ON Semiconductor Soldering and Mounting Techniques Reference Manual, SOLDERRM/D.

DOCUMENT NUMBER:	98AON05189G	Electronic versions are uncontrolled except when accessed directly from the Document Repository. Printed versions are uncontrolled except when stamped "CONTROLLED COPY" in red.
DESCRIPTION:	ECP30, 1.97X4.01	PAGE 1 OF 1

ON Semiconductor and are trademarks of Semiconductor Components Industries, LLC dba ON Semiconductor or its subsidiaries in the United States and/or other countries. ON Semiconductor reserves the right to make changes without further notice to any products herein. ON Semiconductor makes no warranty, representation or guarantee regarding the suitability of its products for any particular purpose, nor does ON Semiconductor assume any liability arising out of the application or use of any product or circuit, and specifically disclaims any and all liability, including without limitation special, consequential or incidental damages. ON Semiconductor does not convey any license under its patent rights nor the rights of others.

ON Semiconductor and  are trademarks of Semiconductor Components Industries, LLC dba ON Semiconductor or its subsidiaries in the United States and/or other countries. ON Semiconductor owns the rights to a number of patents, trademarks, copyrights, trade secrets, and other intellectual property. A listing of ON Semiconductor's product/patent coverage may be accessed at www.onsemi.com/site/pdf/Patent-Marking.pdf. ON Semiconductor reserves the right to make changes without further notice to any products herein. ON Semiconductor makes no warranty, representation or guarantee regarding the suitability of its products for any particular purpose, nor does ON Semiconductor assume any liability arising out of the application or use of any product or circuit, and specifically disclaims any and all liability, including without limitation special, consequential or incidental damages. Buyer is responsible for its products and applications using ON Semiconductor products, including compliance with all laws, regulations and safety requirements or standards, regardless of any support or applications information provided by ON Semiconductor. "Typical" parameters which may be provided in ON Semiconductor data sheets and/or specifications can and do vary in different applications and actual performance may vary over time. All operating parameters, including "Typicals" must be validated for each customer application by customer's technical experts. ON Semiconductor does not convey any license under its patent rights nor the rights of others. ON Semiconductor products are not designed, intended, or authorized for use as a critical component in life support systems or any FDA Class 3 medical devices or medical devices with a same or similar classification in a foreign jurisdiction or any devices intended for implantation in the human body. Should Buyer purchase or use ON Semiconductor products for any such unintended or unauthorized application, Buyer shall indemnify and hold ON Semiconductor and its officers, employees, subsidiaries, affiliates, and distributors harmless against all claims, costs, damages, and expenses, and reasonable attorney fees arising out of, directly or indirectly, any claim of personal injury or death associated with such unintended or unauthorized use, even if such claim alleges that ON Semiconductor was negligent regarding the design or manufacture of the part. ON Semiconductor is an Equal Opportunity/Affirmative Action Employer. This literature is subject to all applicable copyright laws and is not for resale in any manner.

PUBLICATION ORDERING INFORMATION

LITERATURE FULFILLMENT:

Email Requests to: orderlit@onsemi.com

ON Semiconductor Website: www.onsemi.com

TECHNICAL SUPPORT

North American Technical Support:
Voice Mail: 1 800-282-9855 Toll Free USA/Canada
Phone: 011 421 33 790 2910

Europe, Middle East and Africa Technical Support:

Phone: 00421 33 790 2910

For additional information, please contact your local Sales Representative

Mouser Electronics

Authorized Distributor

Click to View Pricing, Inventory, Delivery & Lifecycle Information:

[onsemi:](#)

[LC05732A03RATBG](#)